

RAPID CONTROLS

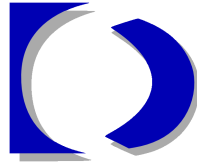

SAB-A USER MANUAL

LDT to Analog Converter

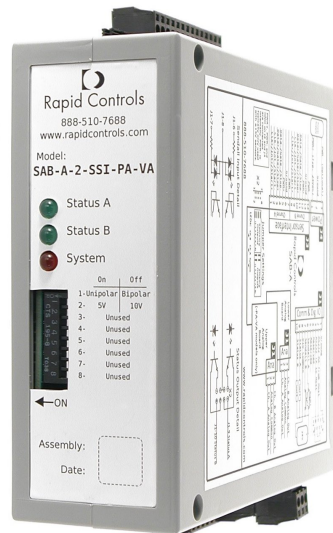

Contents

1 Introduction	2
1.1 Description	
1.2 Features	
1.3 Models and Ordering Information	
2 Installation	4
2.1 Connections	
3 Configuration	6
3.1 Jumpers and DIP Switches	
3.2 Setup Menu	
4 General Operation	12
4.1 Startup	
4.2 Sensor Processing	
4.3 Status	

1 Introduction

1.1 Description

The SAB-A converts two channels of magnetostrictive transducer position and velocity to two or four analog voltage outputs. To achieve accurate, low-latency output, the conversion is implemented using a micro-controller, EPLD, and 16-bit digital to analog converters.

The SAB-A continually interrogates the sensors for position data at a configurable rate. Immediately after each position update, velocity data is calculated from the collected position data. The analog outputs are then set based on the most recent data available.

Sensor update rate, velocity window size, and analog output scaling and offsetting are configurable using a text-based menu accessible via an RS-232 serial port. Status LEDs provide visual confirmation of proper sensor operation. A *Sensor OK* output for each channel allows an external device to monitor sensor interface status.

Although the SAB-A was designed for use with magnetostrictive linear displacement transducers, it can be used with other types of sensors such as glass scales or encoders. To be used with the SAB-A, a sensor must be compatible with the one of the sensor protocols supported by the SAB-A: SSI, Start/Stop, or PWM.

1.2 Features

- Two channels of position from Start/Stop, PWM or SSI magnetostrictive transducers
- 16-bit analog outputs (0.3 mV resolution) with selectable output voltage range
- Voltage range options: -10 to 10V, 0 to 10V, -5 to 5V, 0 to 5V
- Supports arbitrary SSI sensor resolution
- 56 MHz oscillator provides 0.002 inch resolution without recirculation for Start/Stop or PWM sensors (Internal recirculations may be used to increase this)
- Allows controlling all analog outputs from a single sensor with different scaling
- Transducer OK output and LED signals valid transducer operation
- Software selectable update rate, velocity window, and analog position/velocity scaling and offsetting
- Setup via RS-232 serial interface
- Blinking LED indicates good operation of SAB-A
- Watchdog timer for reset upon software failure
- Non-volatile memory for storage of setup parameters

- Convenient screw terminal connections
- $4.64 \times 5.31 \times 1.77$ (D×H×W) inch DIN rail mount enclosure

1.3 Models and Ordering Information

Table 1.1 shows the available SAB-A models. SAB-A units are available with 2 or 4 analog outputs and with support for SSI or Start/Stop and PWM sensors.

Model Number	Channels	Sensor Interface	Position Output	Velocity Output
SAB-A-RPM-PA	2	Start/Stop & PWM	2× 16-bit	---
SAB-A-RPM-VA	2	Start/Stop & PWM	---	2× 16-bit
SAB-A-RPM-PA-VA	2	Start/Stop & PWM	2× 16-bit	2× 16-bit
SAB-A-SSI-PA	2	SSI	2× 16-bit	---
SAB-A-SSI-VA	2	SSI	---	2× 16-bit
SAB-A-SSI-PA-VA	2	SSI	2× 16-bit	2× 16-bit

Table 1.1 SAB-A Models and Ordering Information

2 Installation

2.1 Connections

The connectors of the SAB-A are shown in Figure 2.1. A diagram of these connectors is shown in Figure 2.2. Finally, Table 2.1] shows the pinout of the connectors.

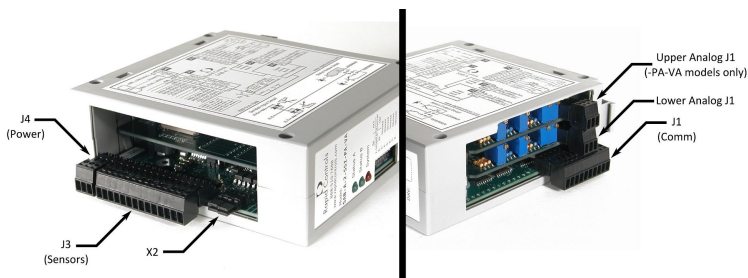

Figure 2.1 SAB-A Connector Locations

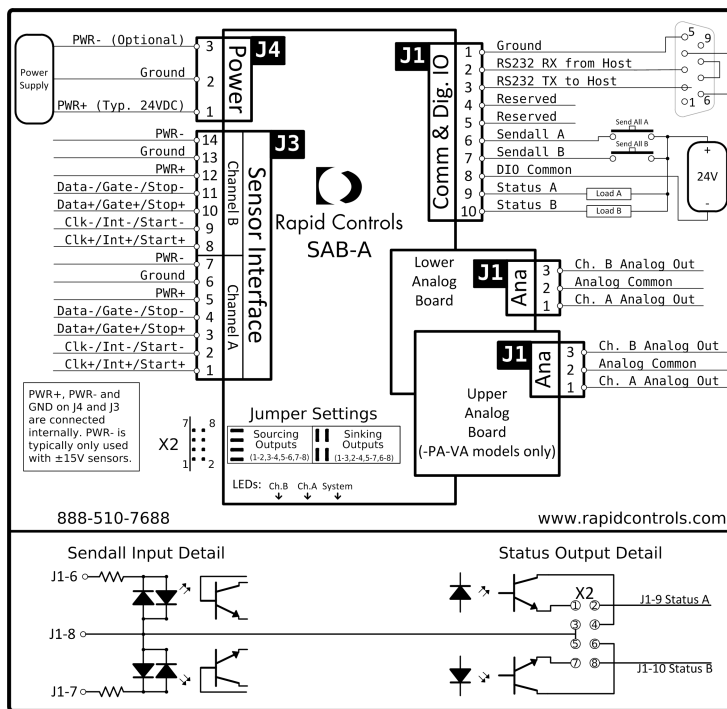

Figure 2.2 SAB-A Connector Placement

Pin	Function	Pin	Function
J1-1	Logic Ground	J3-1	Ch A Clock+ to Sensor
J1-2	RS-232 RX from Host	J3-2	Ch A Clock– to Sensor
J1-3	RS-232 TX to Host	J3-3	Ch A Data+ from Sensor
J1-4	Reserved	J3-4	Ch A Data– from Sensor
J1-5	Reserved	J3-5	+24VDC Power to Sensor
J1-6	Input 1	J3-6	Ground
J1-7	Input 2	J3-7	No Connect
J1-8	Input Common	J3-8	Ch B Clock+ to Sensor
J1-9	Ch0 Sensor Status Output	J3-9	Ch B Clock– to Sensor
J1-10	Ch1 Sensor Status Output	J3-10	Ch B Data+ from Sensor
		J3-11	Ch B Data– from Sensor
J4-1	+24 or +15VDC Power	J3-12	+24 or +15VDC Power to Sensor
J4-2	Power common and signal ground	J3-13	Ground
J4-3	-15VDC Power (Optional)	J3-14	-15VDC Power to Sensor (if needed)
Analog J1-1 (Pos)	Ch A Position Analog Out	Analog J1-1 (Vel)	Ch A Velocity Analog Out
Analog J1-2 (Pos)	Analog Ground	Analog J1-2 (Vel)	Analog Ground
Analog J1-3 (Pos)	Ch B Position Analog Out	Analog J1-3 (Vel)	Ch B Velocity Analog Out

Table 2.1 SAB-A Connector Pinouts

3 Configuration

3.1 Jumpers and DIP Switches

3.1.1 DIP Switch S1

Dip switch S1 is used to select the desired analog output voltage range for all of the analog output channels. The voltage range can be configured to operate with one of these output ranges: -10 to 10 V, 0 to 10V, -5 to 5V, and 0 to 5V. The SAB-A's analog outputs will maintain 16-bit resolution in any of the voltage output ranges.

Switch	Description	Switch Off	Switch On
S1-1	Analog voltage bipolar/unipolar range select	Bipolar	Unipolar
S1-2	Analog voltage 10V/5V range select	10V	5V
S1-3	Unused	---	---
S1-4	Unused	---	---
S1-5	Unused	---	---
S1-6	Unused	---	---
S1-7	Unused	---	---
S1-8	Unused	---	---

Table 3.1 Dip Switch S1 Settings

For example, to configure the analog outputs to be 0 to 10V, set switch S1-1 On (unipolar mode) and switch S1-2 Off (10V).

3.1.2 Jumper X2

Jumper X2 sets the output mode of the sensor status outputs, sinking or sourcing. The status outputs must be configured to match the common applied to J1-8. If ground is applied to J1-8 the outputs must be sinking. If a voltage (+12 to +24 VDC) is applied to J1-8 the outputs will source the voltage.

Shunt Placement	Output Mode	J1-8 Connection
1-3, 5-7, 2-4 & 6-8	Sinking	Ground
1-2, 3-4, 5-6 & 7-8	Sourcing	+12 to +24 VDC

Table 3.2 Jumper X2 Settings

3.2 Setup Menu

Configuration of the SAB-A is accomplished through an interactive setup menu. The setup items accessible in this menu are stored in non-volatile memory.

The setup menu can be accessed via an RS-232 serial connection using a computer or other terminal device connected to the J1 connector. The connection should be established using the parameters shown in Table 3.3. To access the setup menu, transmit three escape (*ASCII 27*) characters rapidly. The SAB-A will display a setup menu and prompt for further input.

The setup menu will display a list of parameters and values. Each of these parameters may be changed by transmitting the letter shown next to the parameter. In addition to the setup parameters, the menu shows the position most recently gathered from the sensors.

After changes have been made, the changed parameters must be committed to non-volatile memory or they will be lost when power is removed from the SAB-A. Choose *Save to EEPROM* to save all parameters to non-volatile memory. To exit the setup menu and return to normal operation, choose *Quit* from the menu (transmit the letter 'Q') or cycle power to the SAB-A.

Parameter	Configuration
Baud Rate	9600 bps
Data Bits	8
Parity	None
Stop Bits	1
Handshaking	None

Table 3.3 Serial Parameters

3.2.1 Default Configuration

A set of default parameters (see Table 3.4) are stored in the SAB-A when it leaves the factory. The default parameters can be restored by selecting the *Factory Defaults* option from the setup menu.

Setup Item	Default Value
Detected Update Time	N/A
Transducer Update Time	2 ms
Eavesdrop Mode	Normal
Transducer Type	24-bit SSI
SSI Protocol	Binary
Analog Position Start	0 counts
Analog Position Range	100000 counts
Analog Velocity Range	100000 counts/s
Velocity Output Type	Velocity
Velocity Window Size	50 transducer update periods

Table 3.4 SAB-A Default Configuration

3.2.2 Configuration Parameters

3.2.2.1 Eavesdrop Mode

Eavesdropping mode allows the SAB-A to monitor data from a sensor that an external device is interrogating. When eavesdrop mode is enabled, the SAB-A monitors the communication between the external devices and the sensor to collect sensor data. The sensor update period is automatically detected.

Eavesdrop mode can be set to one of two modes: *Normal* or *Eavesdrop*. In normal mode, the sensor is interrogated by the SAB-A. In eavesdrop mode, the sensor is interrogated by an external device.

3.2.2.2 Detected Update Time

The detected update time is a read-only value that is only valid when operating in eavesdrop mode (see 3.2.2.1.) The update time is detected by monitoring the interrogate pulses received from the external device that is interrogating the sensor.

When operating in normal, non-eavesdrop mode, this value should be ignored; the update period can be set by changing the Transducer Update Time setup item.

3.2.2.3 Transducer Type

The transducer type selects the protocol used to communicate with the attached sensor. Available options are SSI 24, SSI 25, Start/Stop, PWM, and Copy Other. The SSI options indicate the

number of bits returned by the transducer and should be used with SAB-A-SSI models. The Start/Stop and PWM settings are to be used with SAB-A-RPM models.

The Copy Other option is a special option that causes the selected channel to use the position information from the other channel. This mode is designed for operation with a single sensor. Although the position information is copied from the other channel, the setup items may differ between the channels. For example, the 2nd channel could have a different velocity window size or a different analog range.

Menu Selection	Required Model	Sensor Protocol	Notes
SSI 24	SAB-A-SSI-*	SSI	24-bit data word
SSI 25	SAB-A-SSI-*	SSI	25-bit data word
Start/Stop	SAB-A-RPM-*	Start/Stop	
PWM	SAB-A-RPM-*	PWM	
Copy Other	Any	None	Data copied from other channel

Table 3.5 Transducer Type Settings

3.2.2.4 SSI Protocol

SSI sensors are available with two coding schemes: binary and graycode. The SAB-A supports either scheme. Set the SSI Protocol to *Binary* for binary-output SSI sensors and *Graycode* for graycode-output SSI sensors. If the wrong coding scheme is selected, position data will appear to jump around instead of changing smoothly.

3.2.2.5 Transducer Update Time

The transducer update time is the number of milliseconds between each update of the transducer position information. When using a magnetostrictive transducer, the update time must be long enough to allow the strain pulse to travel the length of the wand. The wavespeed of a typical magnetostrictive transducer is $9 \mu\text{s} / \text{inch}$. If a sensor with internal recirculations are used, multiply the required time by the number of recirculations.

If the update time is set to a value that does not allow for propagation of the strain pulse, the position data will be unstable. See Table 3.6 for a list of possible update time settings.

If the sensor used is not a magnetostrictive transducer, configure the update time as instructed by the manufacturer of the sensor.

Sensor Length (in)	Recirculations	Update Time (ms)
1 - 100	1	1
101 - 200	1	2
201 - 300	1	3
301 - 400	1	4
1 - 50	2	1
51 - 100	2	2
101 - 150	2	3
200 - 201	2	4
1 - 25	4	1
26 - 50	4	2
51 - 75	4	3
76 - 100	4	4

Table 3.6 Suggested Update Times

3.2.2.6 Velocity Window Size

The velocity window size determines how many historical position updates are included in the calculation of the velocity output. For example, if the velocity window size is 10, the current position and the position 10 transducer updates ago are used to calculate the velocity.

3.2.2.7 Analog Position Start

The analog position start is the number of counts which corresponds to the minimum analog output value ($-10V$, $-5V$, or $0V$ DC.) Any position less than the analog position start will be output as the minimum analog output value.

3.2.2.8 Analog Position Range

The analog position range parameter sets the number of counts covered by the total range of the analog position output. For example, if the analog output voltage range is -10 to $10V$, analog position start is 5000 and analog position range is 25000, output will be $-10V$ at 5000 or less counts, $0V$ at 17500 counts, and $10V$ at 30000 counts and higher.

3.2.2.9 Analog Velocity Range

The analog velocity range parameter sets the number of counts/sec covered by each half of the analog velocity output. For example, if the analog output voltage range is -10 to $10V$ and the

analog velocity range is 20000, the output will be -10V at -20000 counts/sec, 0V at 0 counts/sec, and 10V at 20000 counts/sec. 0V is always output when the speed is 0 counts/second.

3.2.2.10 Velocity Output Type

The analog velocity output type parameter controls the style of the velocity analog outputs. One of two options may be selected: velocity or speed. When speed is selected, the absolute value of the velocity is output. When speed is selected, a speed of zero is output as the lowest possible analog output voltage; when velocity is selected, a velocity of zero is output at the center of the voltage range.

3.2.2.11 Save to EEPROM

Select this item to save the values to non-volatile memory. Any configuration items changed will not be saved until this is selected.

3.2.2.12 Load from EEPROM

Select this item to load the values from the non-volatile memory. This will revert any changes made since the last time values were saved to non-volatile memory.

3.2.2.13 Factory Defaults

Select this item to change all of the setup values to the factory defaults, as shown in Table 3.4. Defaults are not saved to non-volatile memory until the *Save to EEPROM* menu item is selected.

3.2.2.14 Quit

Select this item to exit setup and return to normal operation. The configuration values entered via the setup menu will be in effect at this point. Any values not saved to the EEPROM will be lost when power is removed.

4 General Operation

4.1 Startup

At power-on, the board will print a sign-on message indicating the date of software in the board and the status of the retrieval of data stored in the non-volatile EEPROM. A message similar to the following is displayed:

```
Rapid Controls Inc. SAB-A
Copyright(c) 1997-2010 Rapid Controls Inc. 03-01-2010
EEPROM load successful.
```

4.2 Sensor Processing

The SAB-A interfaces with two magnetostrictive transducers and interrogates the sensors for position information at a user-defined rate. After valid sensor data is received on a sensor interface channel, the data is processed as shown in Figure 4.1. Position data history over a user defined window is stored for use in velocity calculation. Scaling and offsetting is performed on the position and velocity data before output via 16-bit DAC.

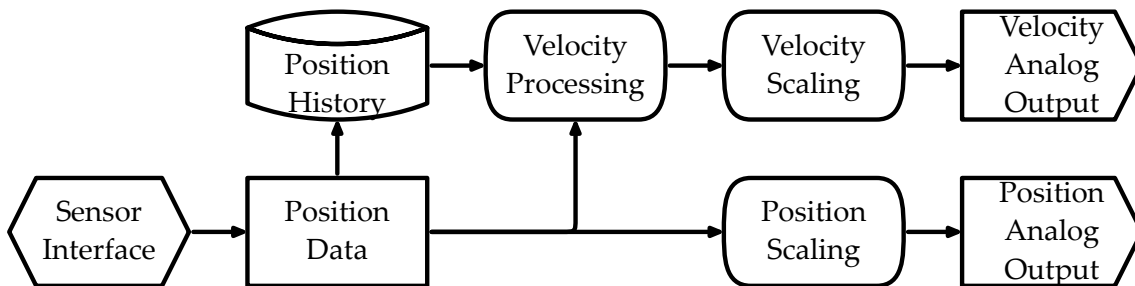

Figure 4.1 Sensor Data Processing for One Channel

4.2.1 Sensor Interface

Each sensor interface is capable of interfacing with sensors supporting three protocols commonly used with magnetostrictive transducers: SSI, Start/Stop and Pulse-Width Modulated (PWM). Other types of sensors, such as absolute encoders, laser rangefinders, and glass scales support the SSI protocol and are compatible with the SAB-A.

SAB-A-SSI models support SSI protocol sensors. SAB-A-RPM models support Start/Stop and PWM protocol sensors.

Each sensor interface can operate in one of two modes: normal mode and eavesdropping mode. In normal mode, the sensor is interrogated at a fixed update rate. In eavesdropping mode, an external master device must interrogate the sensor. The SAB-A monitors the communications between the external master and the sensor. Position data is stored each time the sensor is interrogated.

4.2.2 Velocity Calculation

After position data is received, the data is stored in a circular queue. This queue holds a configurable amount of historical position data. Each time new position data is received, this position data, along with the historical position data, is used to calculate a velocity value.

$$V = \frac{P_0 - P_{-n}}{n \times T_S} \quad (4.1)$$

Equation 4.1 shows the calculation used to determine velocity. V is the velocity in units per second. n is the windows size. P_0 is the current position, P_{-n} is the oldest position information in the window. T_S is the sensor update period in seconds.

4.2.3 Scaling and Output

After sensor data is received and velocity data is calculated, the data is scaled and offset. The configuration parameters Analog Position Start, Analog Position Range, and Analog Velocity Range are used to control this process.

4.3 Status

A red LED on the board blinks during operation. Two green LEDs indicate the status of the transducers. A lit LED indicates a good transducer, and a dim or dark LED indicates a missing or failing transducer or magnet. Sensor status may also be read via the digital outputs. See Section 3.1.2 for information on configuring the digital outputs for sinking or sourcing operation.